

GC Implant Aadva™

Clinical Manual

GC Tech.Europe



Contents

I	Indications and contraindications	3
II	Primary surgery	5
	1. Choice of Implants	5
	2. Surgical instruments for primary surgery	5
	3. Procedures	5
	3-1. Drill sequence	5
	3-2. Site preparation	9
	3-3. Implant placement	12
	3-4. Cover screw procedure (two-stage surgery)	14
	3-5. Healing screw procedure (one-stage surgery)	15
	3-6. Care after primary surgery	16
III	Secondary surgery	17
	1. Surgical instruments for secondary surgery	17
	2. Healing screw procedure (two-stage surgery)	18
	3. Care after secondary surgery	19
IV	Prosthetics	20
	1. Abutment type, selection guide	20
	2. Pre-Prosthetic Steps	21
	2-1. Cement-retained superstructure	21
	2-2. Screw-retained superstructure	23
	3. Impression taking	25
	3-1. Transfer impression <implant level>	26
	3-2. Pick-up impression <implant level>	27
	3-3. Transfer impression <abutment level>	28
	3-4. Pick-up impression <abutment level>	29
V	Management after attaching the superstructure	31
VI	Procedural problems	33
VII	Disinfection/Sterilization of Components and Instruments	33

Indications and contraindications

Various factors should be considered when determining whether implants are an appropriate therapy for the patient. Based on thorough analysis and appropriate diagnosis, the applicability of an implant can be determined. The following indications and contraindications must be considered before making a final decision:

1. Indications

1.1. Indications for implant treatment:

- Partial and total edentulism
- Poor tooth prognosis
- Improvement of oral-health related quality of life
- Avoidance of tooth preparation
- Development of natural tooth appearance
- Preservation of crestal volume
- Improvement of denture retention and stabilisation

1.2. Special indications – GC Aadva Short Implant

GC Aadva Short Implant is indicated for use in the mandible with reduced vertical bone dimension that can accommodate GC Aadva Short Implant without impeding the mandibular canal and its content. Short implant is to be placed with the rough portion being submerged, leaving the polished part at the crestal level. In the case of partial bridges, a Ø4.2-mm Short Implant should always be restored with a splinted prosthetic restoration including additional adjacent implant(s). Ø5.2 mm Short Implants can be used for single-unit restorations of cases with good crown-to-implant ratio, low masticatory forces, appropriate intermaxillary distance and absence of parafunctional habits or occlusal diseases.

1.3. Special indications – GC Aadva Narrow Implant

GC Aadva Narrow Implant is indicated for patients with low masticatory forces, appropriate intermaxillary distance and absence of parafunctional habits or occlusal diseases.

The following regions present feasible recipient sites:

- Maxillary lateral incisors
- Mandibular incisors

If used in the premolar region, it is recommended that it is restored with a splinted prosthetic restoration including additional adjacent implant(s). GC Aadva Narrow Implant is not indicated for use in the posterior and canine region.

2. Contraindications

2.1. Absolute contraindications:

- Hypersensitivity to titanium or components of titanium alloy
- General medical state precluding minor oral surgical procedures (i.e. recent myocardial infarction/CVI, severe blood disorders, bleeding issues, uncontrollable endocrine disorders, recent valvular prosthesis, severe renal disorder, etc.)
- High dose of radiation and/or chemotherapy
- Intravenous bisphosphonate therapy
- High risk for medication-induced osteonecrosis of the jaw
- Acute inflammation in the recipient region
- Uncontrolled periodontal disease
- Mental health status precluding invasive surgery

2.2. Relative contraindications:

- Low dose radiation therapy in the head and neck region
- Immunocompromised patient
- Systemic and metabolic disease and/or treatment impairing healing and bone physiology
- Oral bisphosphonate therapy
- Low risk for medication related osteonecrosis of the jaw
- Incomplete growth and development
- Inadequate width and height in recipient bone bed or extraction socket
- Chronic inflammation, benign lesions (i.e. tumors, cysts) or trauma in the recipient region
- Parafunctional habits (i.e. bruxism, clenching), trismus, unfavourable intermaxillary distance, occlusal diseases
- Heavy drug, alcohol and/or tobacco use
- Poor oral hygiene



Non-clinical testing has demonstrated that the Aadvia Implant System configuration is MR Conditional. A patient with Aadvia Implants and Abutments can be safely scanned in an MR system meeting the following conditions:

- Static Magnetic Field Strength: 1.5 or 3 T
- Maximum spatial field gradient:
 - 1.5 T: 60.37 T/m (= 6037 G/cm)
 - 3 T: 30.19 T/m (= 3019 G/cm)
- Radiofrequency (RF) field exposure:
 - Radiofrequency excitation: Circularly Polarized (CP)
 - Radiofrequency transmit coil: whole-body transmit coil
 - Radiofrequency receive coil type: whole-body receive coil
 - Maximum permitted whole-body averaged specific absorption rate (SAR): Normal Operating Mode, 2 W/kg

Note:

Under the scan conditions defined above, the Aadvia Implant system configuration is expected to produce a maximum temperature rise of less than 2.3 °C at 1.5 T and less than 2.6 °C at 3 T after 15 minutes of continuous scanning.

In non-clinical testing, the image artefact caused by one implant extends approximately 12 mm from the device edge on gradient echo image, and 13 mm on spin echo images, at 1.5 T.

- ⚠ When carefully planning the implant treatment and the prosthetic restoration always take into consideration that every type of implant, depending on shape, length, diameter, position and bone quality, has a different field of application and indication. Avoid overstressing the implant and osseointegration by inappropriate choice of implant and superstructure. Always follow the current state of the science and clinical treatment guidelines as well as the most up to date recommendations of the appropriate implantological professional societies.

II Primary surgery

1. Choice of Implants

Standard, Tapered, Short

The choice of appropriate implant type, diameter and length must always follow the current state of the science and clinical treatment protocols, as well as the most up to date recommendations of the appropriate implantological professional societies.

Within the range of correct medical indications the following Aadva Implant types can be selected according to their characteristics:

Standard (cylindrical) Implants fit most treatment needs. They are recommended predominantly in harder bone qualities as their shape works less compressively than tapered implants. Shape and modified drill sequence lead to excellent primary stability and moderate insertion torques.

Tapered Implants are recommended in softer bone as, due to their pronounced conical shape, they provide a stronger compressive effect and thus guarantee a good primary stability even in soft bone. They should not be used in hard bone as, in this situation, the pronounced compression effect might be unwanted and result in increased torque during insertion.

Short Implants are recommended in case of low bone height, where augmentative procedures are not desired and reduced prosthetic load is foreseen.

2. Surgical instruments for primary surgery

Surgical motor

Use a surgical motor meeting the following specifications:







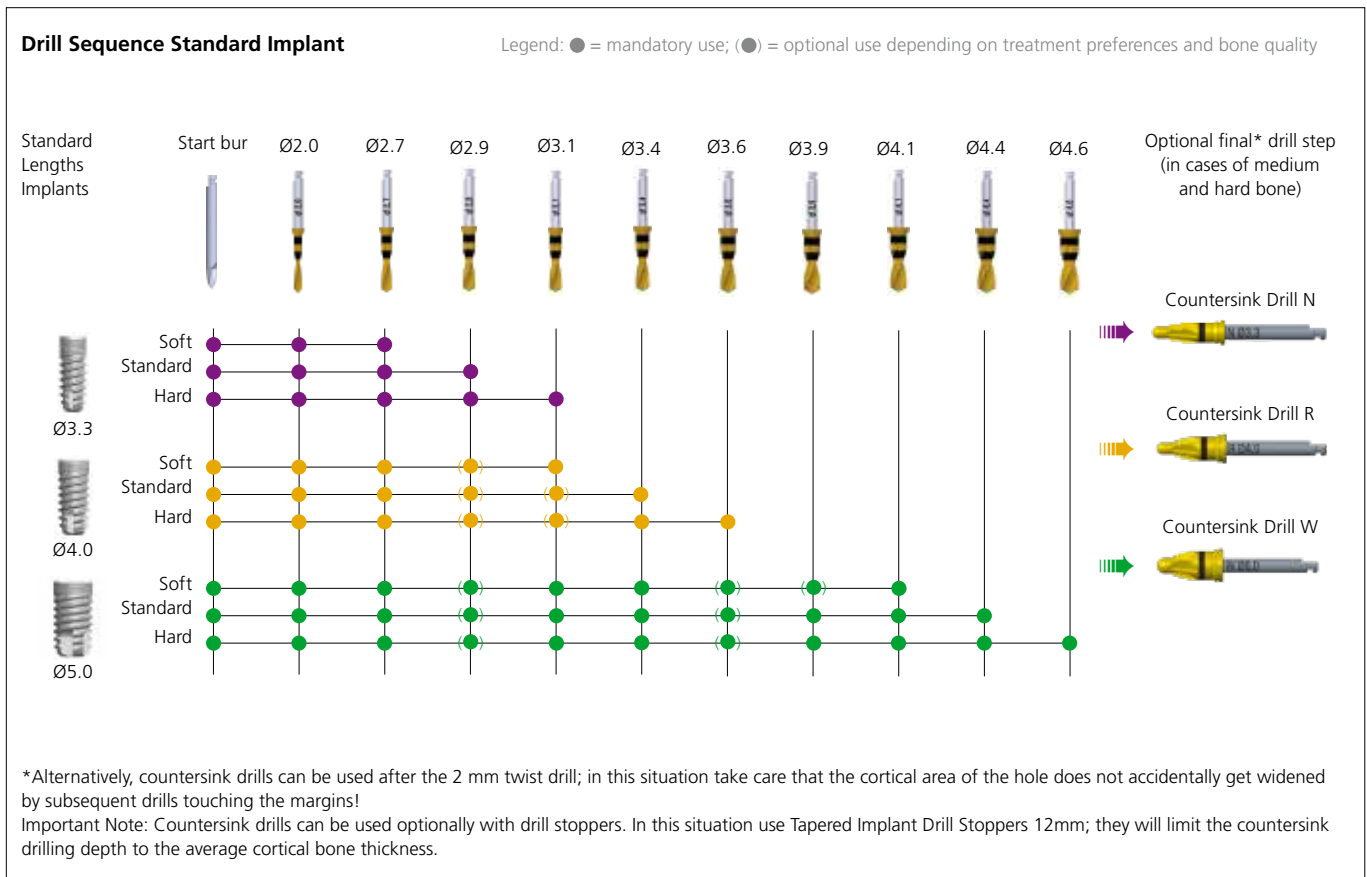















- Speed range: 25 to 1000 rpm.
- Torque control of 10 N-cm to 50 N-cm at low speeds.

3. Procedures

3-1 Drill Sequence



Drill Sequence Tapered Implant

Diameter	Length	Drill Steps				Optional Final Drill Step
		1	2	3	4	(in cases of medium and hard bone)
Narrow	8 mm 			Tapered Implant Drill Narrow 8 mm 		Countersink Drill N 
	10 mm  12 mm  14 mm 			Tapered Implant Drill* Narrow, 10 - 14 mm 		
Regular	8 mm 			Tapered Implant Drill Regular, 8 mm 		Countersink Drill R 
	10 mm  12 mm  14 mm 			Tapered Implant Drill* Regular, 10 - 14 mm 		
Wide	8 mm 				Tapered Implant Drill Wide, 8 mm 	Countersink Drill W 
	10 mm  12 mm 				Tapered Implant Drill* Wide, 10 - 12 mm 	

Drill Sequence Short Implants

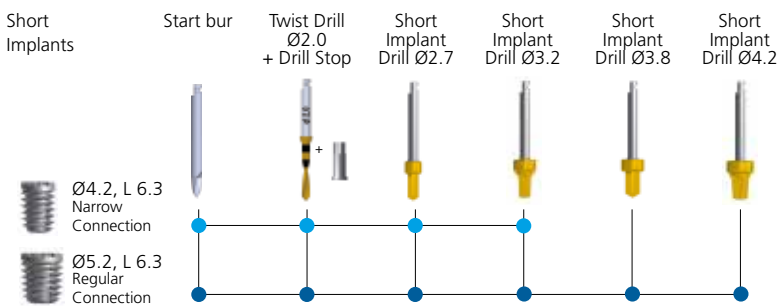

Instruments

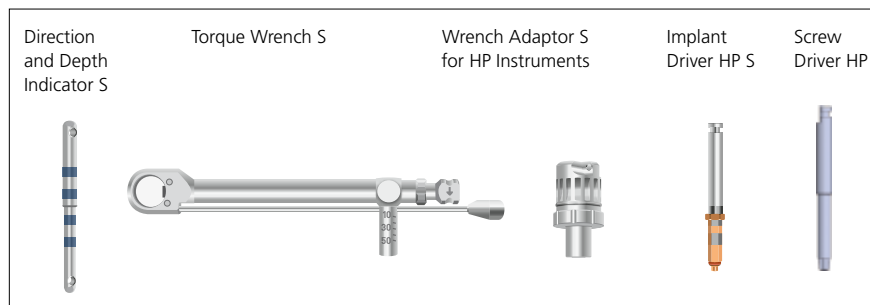

Implant, cover screw, healing screw

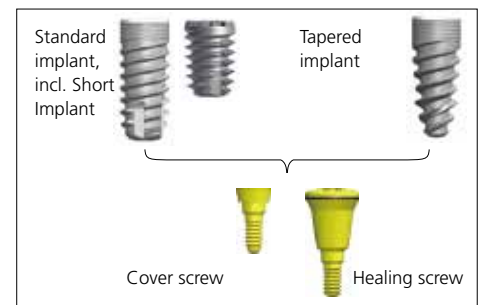

3-1. Drill sequence

- Follow proper surgical protocol including sterilization & handling of sterile items.
- During drilling procedures, do not burn bone tissue.
- Use normal saline during drilling. Raise and lower drill to distribute saline solution and to rinse bone tissue during drilling.
- Make sure that drill is attached firmly to the contra angle.
- Twist drills prepare a hole 1 mm deeper than the end of the applicable implant.
- Insert the implant till the upper surface reaches the marginal bone level, or 0.3 mm above. (Machine surface of standard and tapered implant is 0.3 mm in height and 0.5 mm with short implant.)
- Assess implant position taking into account anatomical landmarks such as the maxillary sinus and mandibular canal, neighbouring tooth and roots, bone substance and implant orientation.
- When placing multiple implants, ensure an appropriate distance between implants and/or natural teeth.
- Use sufficient cooling during drilling.
- The drill carries a laser marking to measure the appropriate depth to which drilling should be carried out.
- Drills must be replaced when cutting performance becomes lower.
- Use drill extensions if the contra angle head interferes with neighbouring teeth, or if the length of the shank is insufficient.
- Do not use the drill extension for any other purpose. Using it for implant driver, screw driver or other bits may cause damage due to the high levels of torque.
- Before use, check that the drill is firmly attached to the drill extension.

Relationships between Implants, Drills, Direction and Depth Indicator

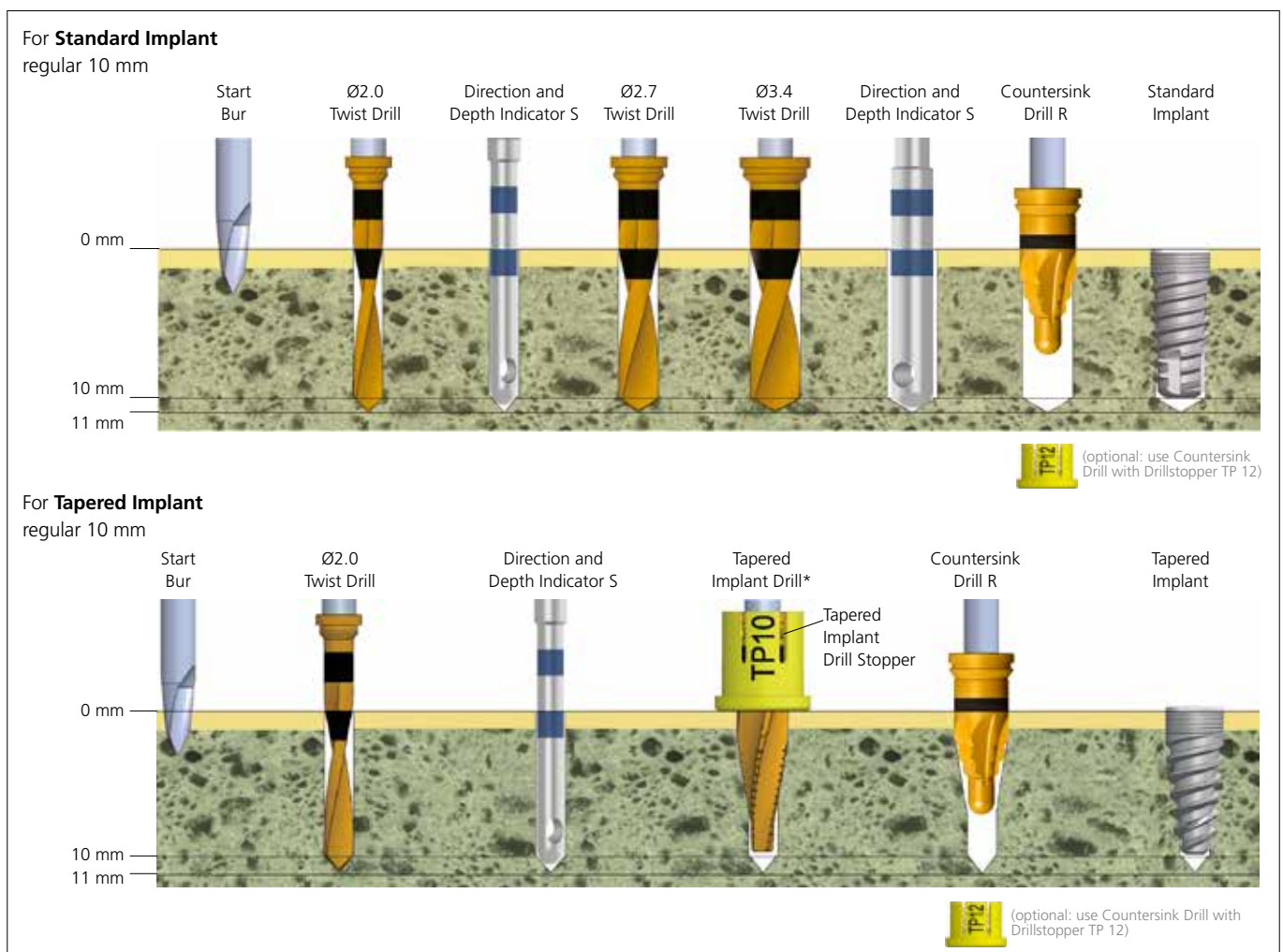

For **Short Implant**

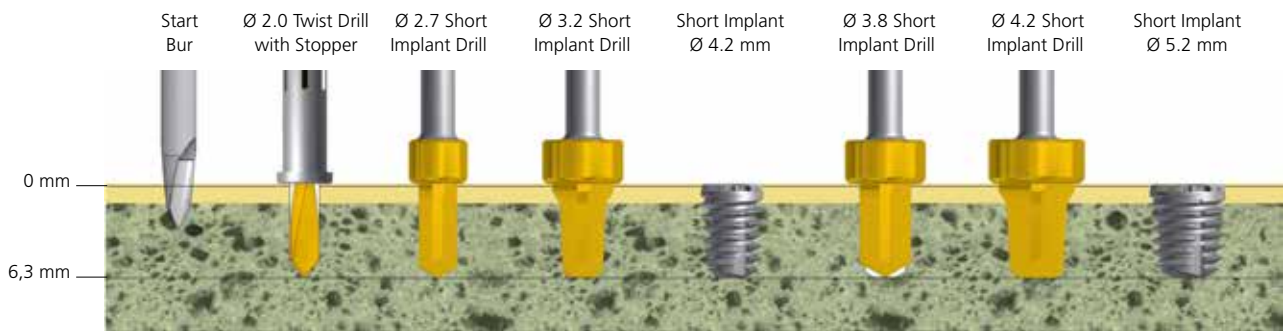

■ **Drill scale**

Twist Drills

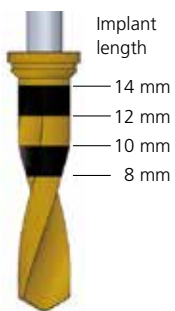

Tapered Implant Drills

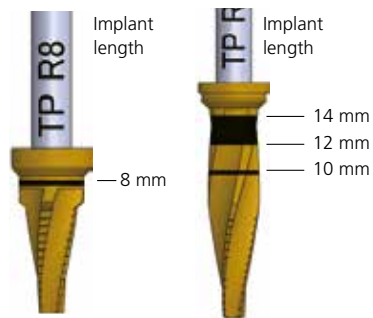

Short Implant Drills



Countersink Drill



Drill Extension



Implant Driver

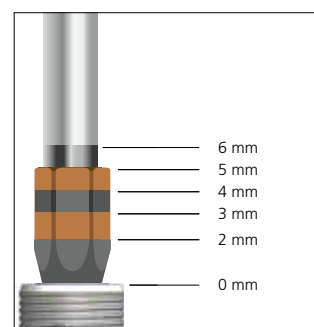

3-2. Site preparation

For **standard implant regular 10 mm**

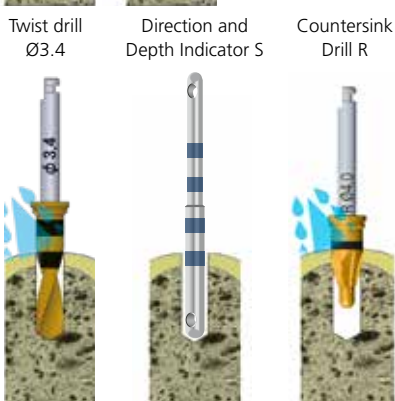
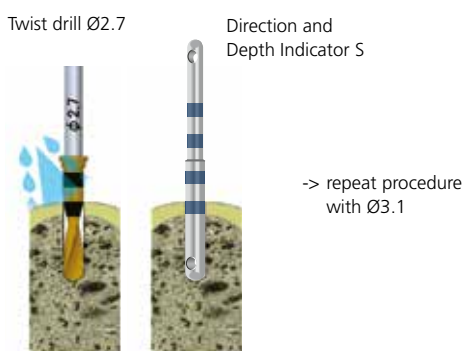
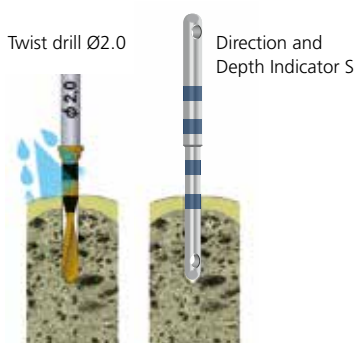
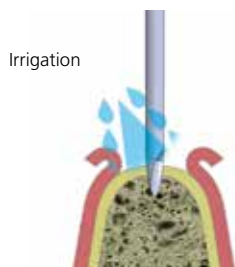

1. Form a starting point with a start bur

- 1000 rpm or less.
- Drill a hole in the cortical bone while checking the implant area with a surgical guide.

⚠ You may want to slant the bur at the beginning of the procedure.

2. Form a hole with twist drill D2.0

- 1000 rpm or less.
- Drill the implant site to the predetermined depth.
- Confirm the direction and depth by inserting the thin end of the Direction and Depth Indicator S

⚠ Tie the Direction and Depth Indicator S to prevent accidental ingestion.

3. Form a hole with twist drill D2.7 and then with D3.1

- 1000 rpm or less.
- Drill the implant site to the predetermined depth.
- Confirm the direction and depth by inserting the thick end of the Direction and Depth Indicator S.

⚠ Tie the Direction and Depth Indicator S to prevent accidental ingestion.

4. Form a hole with twist drill D3.4

- 1000 rpm or less.
- Drill and expand the implant site to the predetermined depth.
- Confirm the direction and depth by inserting the thick end of the Direction and Depth Indicator S.
- In cases with hard cortical bone use a countersink drill to an appropriate depth according to the cortical thickness (laser mark indicates average depth).
Note: Countersink drill can be used with Drill Stopper TP 12 to limit depth to the average cortical thickness.

• Procedures for drilling into soft bone

- Form a hole with a smaller diameter drill, if the bone is soft.

• Procedures for drilling into hard bone

- Use countersink drills, as indicated above, if cortical bone structure is hard.
- Additionally form the hole with a larger diameter drill, if overall bone structure is hard.
- If the surgical motor stops at 50 Ncm while placing the implant, operate the motor in reverse to remove the implant and use one size larger twist drill to form the hole and place the implant again.

⚠ Continuing to place implants at a torque exceeding 50 N-cm may not only cause the implant driver to break, but may also cause the implant to become deformed, possibly impacting upon the fitting of the abutment. Furthermore it will significantly increase the risk of bone tissue damage with negative impact on osseointegration.



For **Tapered implant** regular 10 mm

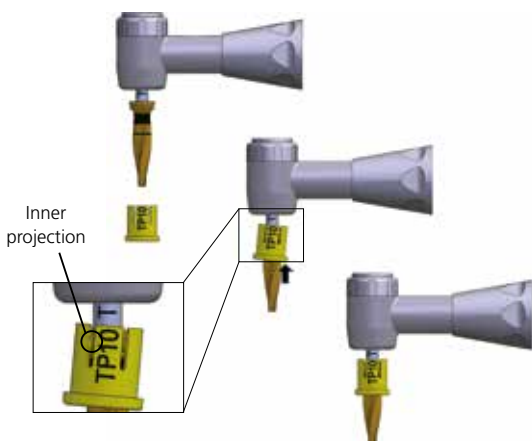
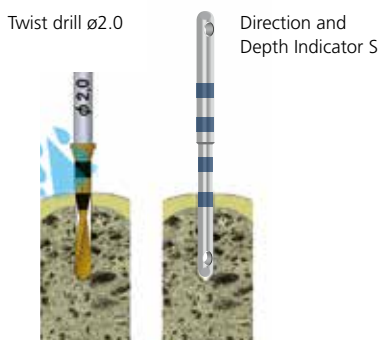
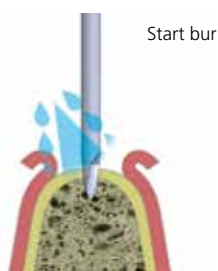

Tapered implant drill* regular

Countersink drill R



1. Form a starting point with a start bur

- 1000 rpm or less.
- Drill a hole in the cortical bone while checking the implant area with a surgical guide.

⚠ You may want to slant the bur at the beginning of the procedure.

2. Form a hole with twist drill D2.0

- 1000 rpm or less.
- Drill the implant site to the predetermined depth.
- Confirm the depth and direction by inserting the thin end of the Direction and Depth Indicator S

⚠ Tie the Direction and Depth Indicator S to prevent accidental ingestion.

3. Insert 'tapered implant drill regular' into 'tapered implant drill stopper for R10'

⚠ Drill stoppers are needed only to make holes to the depth of 10 mm and 12 mm. (They are NOT needed for 8 mm and 14 mm.)

- Before attaching the drill stopper, it is recommended to insert the drill onto the handpiece.

Colour coding:	Narrow	Regular	Wide	
				TP = for tapered implant drill
				10 = for depth 10 mm
				12 = for depth 12 mm

- To attach easily, first tilt the drill stopper and position an inner projection into the groove of the drill. Then, push up the opposite side.
- You can confirm by feeling a click if the drill stopper is attached in the right position.
- Before drilling, to make sure that a proper attachment is done, rotate the drill and confirm there is no decentring visible.

4. Form a hole with tapered implant drill regular and countersink drill

- 500 – 700 rpm.
- Drill and expand the implant site to the predetermined depth.
- Tilting must be avoided to make holes accurately.
- In cases with medium or hard cortical bone use a countersink drill to the appropriate depth according to the cortical thickness (laser mark indicates average depth).

Note: Countersink drill can optionally be used with Drill Stopper TP 12 to limit depth to the average cortical thickness.

- ⚠ When drill stoppers are attached, note that water from a handpiece cannot cool drills effectively under some conditions. In such cases, external cooling by assistants is needed. If water splashes too much, adjust the amount of water or use suction.
- ⚠ Once you confirm that the drill stopper contacts bone, don't push it any more since damage to the bone can be caused.
- ⚠ When decreasing force of attachment/detachment, deformation or abrasion is observed with the drill stopper, stop using it and replace it with a new one.



Procedures for drilling into hard bone

- In cases of medium and hard cortical bone structure use Countersink Drills N, R or W, according to the implant diameter, as described above. However, if overall bone structure is dense and hard, a tapered implant in general is not recommended.

For Short Implant

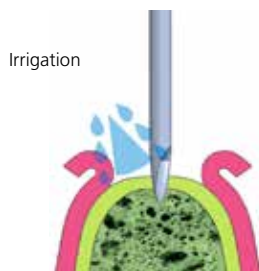

1. Form a starting point with a start bur

- 1000 rpm or less.
- Drill a hole in the cortical bone while checking the implant area with a surgical guide.

⚠ You may want to slant the bur at the beginning of the procedure.



2. Form a hole with twist drill D2.0

- 1000 rpm or less.
- Drill the implant site to the predetermined depth using the drill stopper for a short implant.

3. Form a hole with short implant drills

- 1000 rpm or less.

4. Place short implant

- use surgical motor at max. 25 rpm and/or torque wrench
- limit torque to 50 Ncm max.

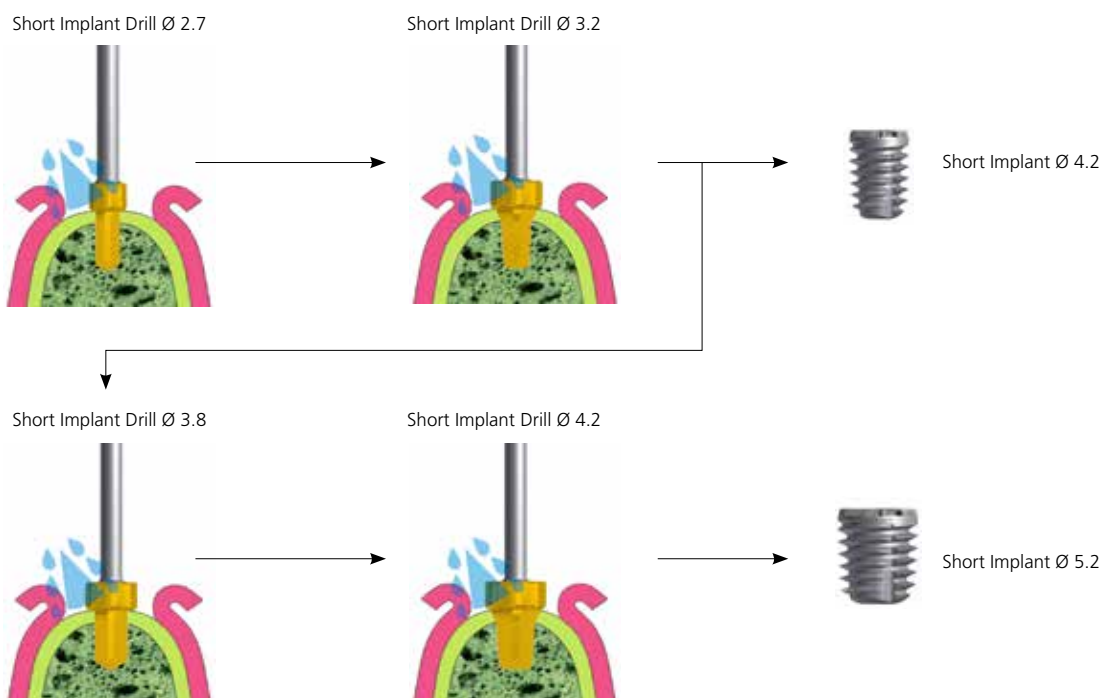

⚠ When planning the prosthetic restoration and loading the implant always take into consideration that a short implant can not, even if perfectly osseointegrated, withstand the same forces as longer implants. Avoid overloading a short implant by an inappropriate superstructure. Always make sure that there is adequate lateral support for a restoration on a short implant. Never use with a terminal single crown in the arch. Always follow the current state of the science and clinical treatment guidelines as well as the most up to date recommendations of the appropriate implantological professional societies.

3-3. Implant placement



N Middle N Long R/W Middle R/W Long

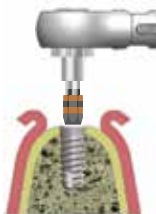
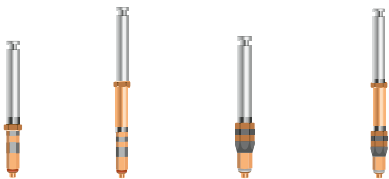

Placement depth



bone level



or 0.3 mm supracrestal
(machine surface of implant
neck above bone level)

1. Implant preparation

- Remove the implant container from the blister pack (the inside of the container has been treated with gamma sterilization).
- Remove the cap of the implant container slowly to avoid dropping the implant.
- ⚠ The blister pack should be opened carefully by the non-sterile assistant, and the implant container by the Clinician.

2. Holding and carrying the implant

- Insert the implant driver in a contra angle.
- Hold the implant container with your finger and push the end of the implant driver into the implant.
- Hold the implant with the cutting blade facing upward and carry it to the patient's mouth to avoid dropping the implant.
- ⚠ Make sure not to contaminate the implant.
- ⚠ Do not use a drill extension.
- ⚠ Insert the driver straight.
- ⚠ Do not apply torque to the driver until it is fully seated in the Implant
- ⚠ Confirm with the following points that the implant has been firmly installed within the driver when you hear a firm click, and the golden section of the driver is hidden.



3. Implant placement

- Place the implant at speeds of 25 rpm or less.
- Start with a low torque depending on bone condition.
- Spray physiological saline solution if the bone substance is hard.

Start sterile irrigation after the cutting blade has completely entered into the bone tissue.

4. Confirm correct seating using a torque wrench.

- Attach the implant driver into the wrench adaptor and the wrench adaptor into the torque wrench.
- Confirm seating of the implant using the torque wrench.
- Align the top of the implant with the marginal bone level or 0.3 mm above.
- Spray physiological saline solution if the bone substance is hard.



- ⚠ Always carefully attach the wrench adaptor onto the torque wrench and the implant driver onto the adaptor firmly, until you feel a click.
- ⚠ Limit implant insertion torque to 50 N·cm or less.
- ⚠ Never use a drill extension with implant drivers.

• Orientation of the implant

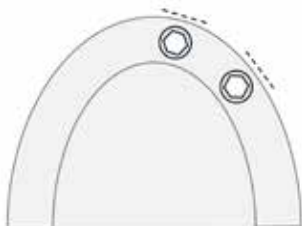

Please note that the rotational orientation of the geometric features of an ancillary component and abutment - angulation, flat surfaces, prosthetic margins etc. - are linked to the flat surfaces of the internal hexagon of the implant. Please assess the desired orientation of your abutment when placing your implant. In most cases a rotational orientation with one flat surface of the internal hexagon parallel to the vestibular surface will be the appropriate choice. The hexagonal shafts of the implant drivers mirror the implant hexagon orientation while inserting the implant.

• Manual placement

- Implants can be placed manually without the use of a surgical motor.

Torque Wrench S, Wrench Adaptor S, Implant Driver S

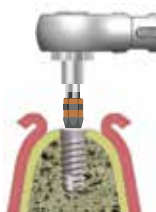
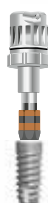
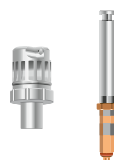

1. Instrument preparation

- Attach the implant driver into the torque wrench adaptor and the adaptor into the torque wrench.
- ⚠ Confirm that the instruments click into place during assembly.
- ⚠ Never use a drill extension with implant drivers.

2. Holding and carrying the implant

- Attach the implant driver to the implant.
- ⚠ Make sure not to contaminate the implant.
- ⚠ Confirm visually that the implant has been firmly installed within the driver.
- ⚠ Confirm with the following two points that the implant has been firmly installed within the driver.

1. Firm click
2. Golden section is hidden



3. Implant placement

- Insert the implant to some extent by hand, and then continue using a torque wrench for placement.
- Spray physiological saline solution if the bone substance is hard.
- ⚠ Limit torque to 50 N·cm or less.
- ⚠ To prevent accidental ingestion, tie instruments with suture or dental floss.

- placement depth see page 11

3-4. Cover screw procedure (two-stage surgery)

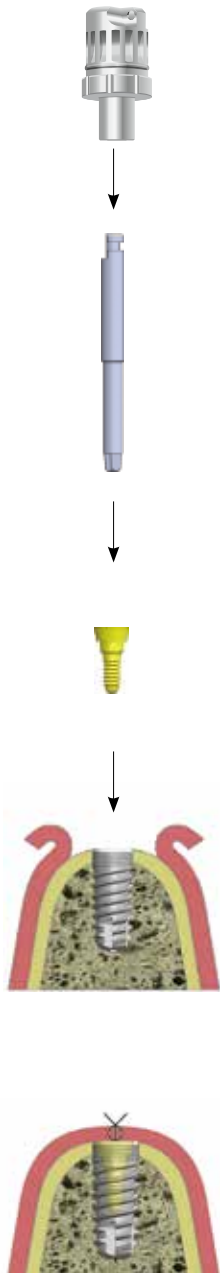

1. Cover screw preparation

- Remove the cover screw from the sterilized pack (the sterilized pack has been treated by gamma sterilization).
- ⚠ Take care of appropriate unpacking and handling in order not to contaminate the sterile screw.

2. Holding, carrying and tightening the cover screw

- Insert the Screw Driver HP into the Torque Wrench Adaptor S.
- Insert and hold the end of the screw driver into the groove at the centre of the cover screw.
- Press the head of the screw driver into the opening at the centre of the cover screw. (The firm hold of the parts depends on the pressure applied.)
- ⚠ Insert the screw driver straight.
- ⚠ Confirm that the screw driver is being held firmly.
- ⚠ Always make sure that the interior of the implant contains no residues of any dental or other materials. If necessary clean and dry appropriately.
- Insert the cover screw into the implant and gently tighten. (10 Ncm or less).
- ⚠ Inserting the screw driver at an angle may cause damage to the inner thread of the implant. Confirm that it is inserted straight and smooth.
- ⚠ To prevent accidental ingestion, tie instruments with suture or dental floss

3. Reattachment and suturing of the mucoperiosteal flap

- Follow an appropriate technique for suturing of the mucoperiosteal flap.

3-5. Healing screw procedure (one-stage surgery)

- Depending on the case, healing screws may be selected for one-stage implants instead of cover screws.

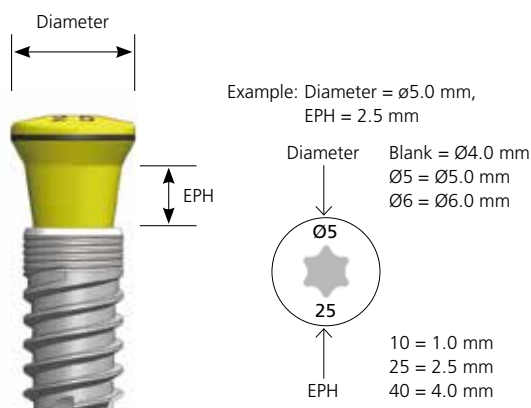

1. Selecting a healing screw

- ⚠ Ideal height of healing screw is about 1 mm above the soft-tissue without causing premature contact with the occluding teeth.

Identify EPH (Emergence Profile Height) and diameter with marking on top surface.

2. Holding, carrying and tightening the healing screw

- Insert the Screw Driver HP into the Torque Wrench Adaptor S.
- Insert and hold the end of the screw driver into the groove at the centre of the cover screw.
- Press the head of the screw driver into the opening at the centre of the healing screw. (The firm hold of the parts depends on the pressure applied).

- ⚠ Insert the screw driver straight.
- ⚠ Confirm that the screw driver is being held firmly.

- ⚠ Always make sure that the interior of the implant contains no residues of any dental or other materials. If necessary clean and dry appropriately.

- Insert the healing screw into the implant and gently tighten. (10 Ncm or less).

- ⚠ Inserting the screw driver at an angle may cause damage to the inner thread of the implant. Confirm that it is inserted straight and smoothly.

- ⚠ To prevent accidental ingestion, tie instruments with suture or dental floss.

3. Suture the mucoperiosteal flap

- ⚠ Avoid loading on the healing screw when placing provisional prostheses.



3-6. Care after primary surgery

When sedation or general anaesthesia has been used, continue observation until the patient is fully awake. Prescribe appropriate antibiotics and analgesics for the content of the surgery and for the patient's weight and age. In order to achieve osseointegration of the implant, it is important that the implant remains undisturbed after installation. Ensure that the patient is given the post-surgical advisory notice and explain its content. Under normal circumstances, with an edentulous jaw, use of dentures is prohibited for about ten days. A predominantly liquid diet should be maintained for ten days. With a partially edentulous situation, depending on the surgical field and residual teeth, it may be possible to eat a more normal diet. Give instructions appropriate for the case. (Example: With a unilateral edentulous situation, mastication may be fully possible on the other side).

When a single implant procedure is selected, connecting a healing screw makes it necessary to adjust the provisional prostheses.

Post-surgical instructions

- Next appointment is ____ / ____ (month / date)
- Please arrive at the clinic by ____ (a.m. / p.m.)
- Avoid rinsing your mouth any more than necessary today.
From tomorrow, rinse your mouth well after each meal.
- Do not exercise, take a bath, or drink alcohol today.
- Refrain from smoking for the time being. Follow your surgeon's instructions on timing for smoking.
- Do not use dentures for at least two weeks after surgery.
Follow your surgeon's instructions.
- Eat only soft food for two weeks after surgery.
- Keep the site of surgery cool today. If the site still seems to be retaining heat tomorrow, cool it with a wet towel or similar, but take care not to cool it excessively.
- Beginning the day after surgery, you may notice some blood mixed with your saliva, but that is not a cause for concern.
If blood is flowing from the wound, bite onto gauze for 30 to 60 minutes.
- Use a pillow to raise your head when you go to bed tonight.
- If you had surgery of the upper jaw, there may be a little nosebleed today. Do not blow your nose strongly for 3 days.
- Do not use a toothbrush on the surgical site until the sutures have been removed.
- Follow the instructions carefully for the medications you have been prescribed.
- Contact your surgeon if you experience any problems, such as excessive bleeding or pain.

1. Post-operative management

Remove sutures after about 7-10 days from the primary surgery, after examining the state of the surgical site.

2. Time required for healing

The healing period between the surgeries is normally at least 3 months for the lower jaw, and at least 6 months for the upper jaw. If the bone substance is poor and the implant was not firmly fixed in the primary surgery, a longer healing time may be required.

III Secondary surgery

1. Surgical instruments for secondary surgery

Surgical motor

Use a surgical motor meeting the following specifications:
 Speed range: 25 rpm or less.
 Set torque for at least 10 N·cm.

Instruments

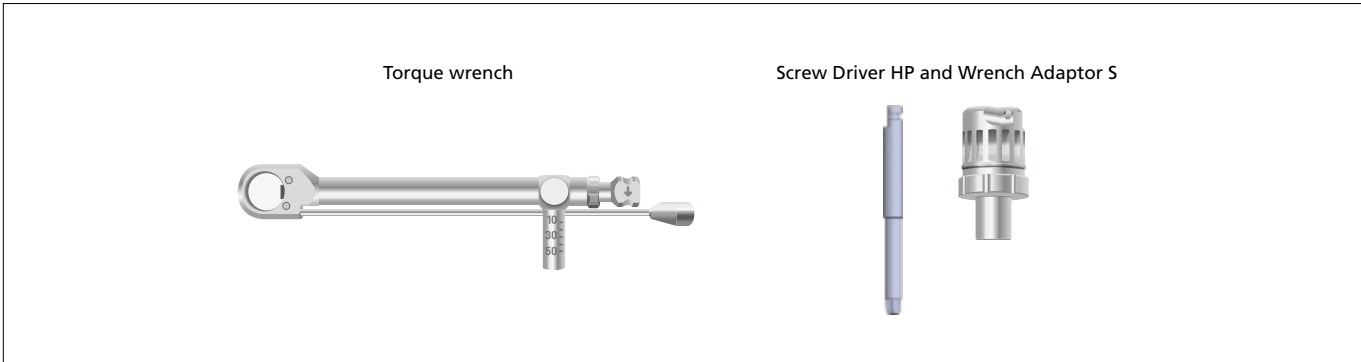

Healing screw

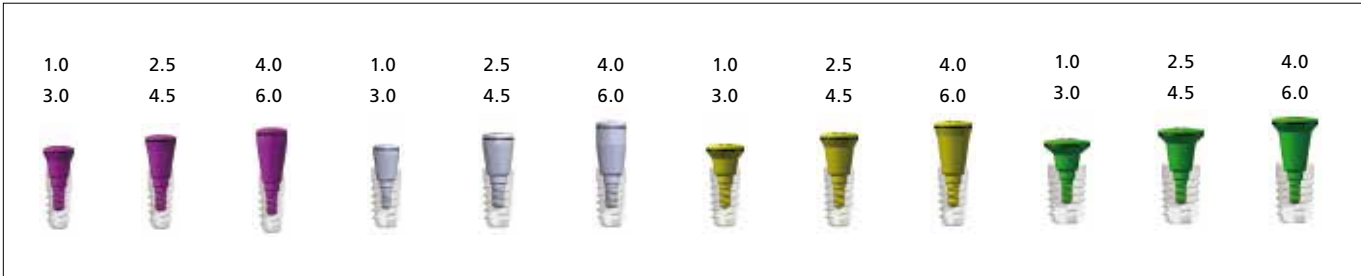

2. Healing screw procedure (two-stage surgery)

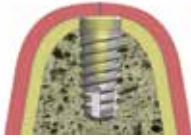

1. Removing cover screw

- Open the mucosa over the implant.
- Remove the cover screw with screw driver.
- Clean internal surfaces of implant.



2. Select a healing screw

- Determine the height of the healing screw based on the thickness of the soft-tissue.
- ⚠ Ideal height of healing screw is about 1 mm above the soft-tissue and does not cause premature contact with the occluding teeth.
- ⚠ Always make sure that the interior of the implant contains no residues of any dental or other materials. If necessary clean and dry appropriately.

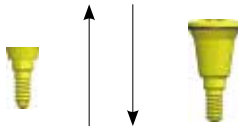

3. Placing healing screw

- Press the head of the screw driver into the opening at the centre of the healing screw and screw the healing screw into the implant.
- Tighten to a torque of 10 N-cm with the screw driver HP or the screw driver wrench.
- Avoid loading on the healing screw when placing the provisional prosthesis.
- ⚠ To prevent accidental ingestion, thread suture into screw driver.

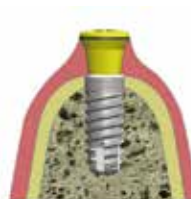

4. Suture the gingival flap

3. Care after second surgery

Prescribe appropriate antibiotics and analgesics. Ensure that the patient is given the post-surgical care instructions and that the contents have been explained.

The sutures can be removed after about 7-10 days post-operatively, after examining the state of the surgical site.

When a healing screw is connected, a provisional prosthesis may no longer fit, so adjustments may be necessary.

Post-surgical care instructions

- Next appointment is ____ / ____ (month / date)
- Please arrive at the clinic by ____ (a.m. / p.m.)
- Avoid rinsing your mouth any more than necessary today.
From tomorrow, rinse your mouth well after each meal.
- Do not exercise, take a bath, or drink alcohol today.
- Refrain from smoking for the time being. Follow your surgeon's instructions on timing for smoking.
- Do not use dentures for at least two weeks after surgery.
Follow your surgeon's instructions.
- Beginning the day after surgery, you may notice some blood mixed with your saliva, but that is not a cause for concern.
If blood is flowing from the wound, bite onto gauze for 30 to 60 minutes.
- Do not use a toothbrush on the surgical site until the sutures have been removed.
- Follow the instructions carefully for the medications you have been prescribed.
- Contact your surgeon if you experience any problems such as excessive bleeding or pain.

IV Prosthetics

1. Abutment type, selection guide

- Select the appropriate type of abutment for each clinical case.
- The CAD/CAM abutment or UCLA abutment is suitable for designing the subgingival shape to take individual shape into account.

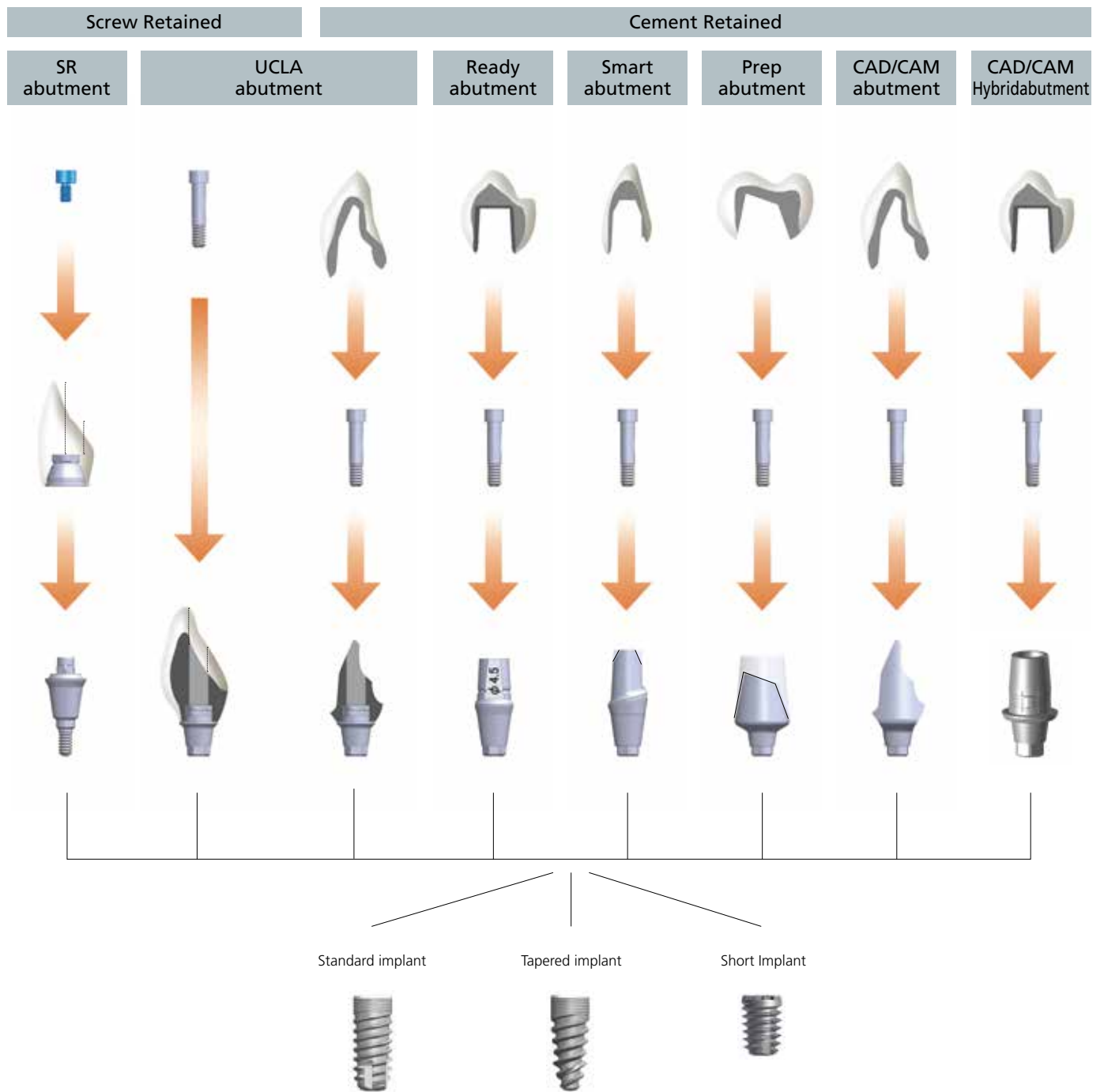

2. Pre-prosthetic steps

2-1. Cement-retained superstructure

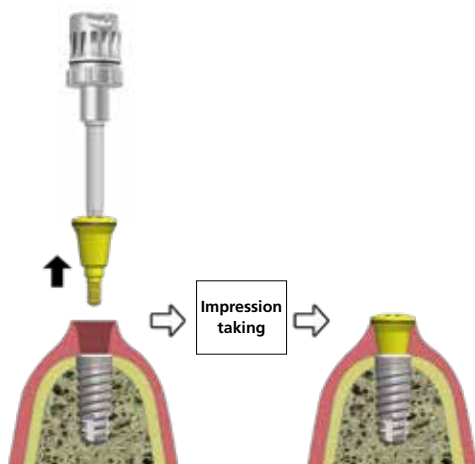

Smart abutment, Prep abutment, UCLA abutment, CAD/CAM abutment

1. Preparation

- Remove the healing screw with a screw driver.
- After taking the impression, re-install the healing screw.
- ⚠ Make sure all impression material has been thoroughly removed before replacing the healing screw.

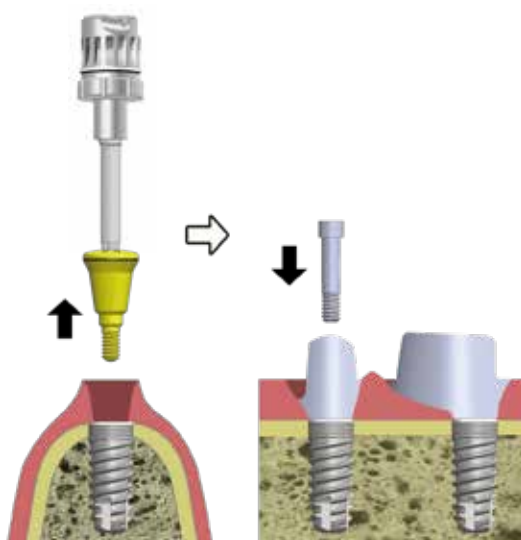

2. Abutment placement

- Remove the healing screw with a screw driver. Connect the prepared and finished abutment to the implant body with the torque wrench. (20 N-cm maximum).
- ⚠ Prior to placement, check that the top of the implant body is free from tissue or residue.
- ⚠ If required, take an X-ray to confirm the connection between the abutment and the implant body.
- ⚠ Check the shape and position of the abutment to avoid excess lateral force on the implant body.



3. Provisional luting of the final prosthesis

Lute the prosthesis with provisional cement such as GC Freegenol, carefully removing excess cement from the margins.

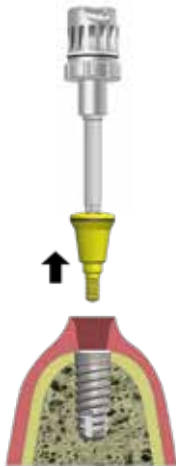

Ready abutment

1. Preparation

- Remove the healing screw with a screw driver.
- Select the appropriate height of ready abutment for each clinical case.

2. Placing the abutment

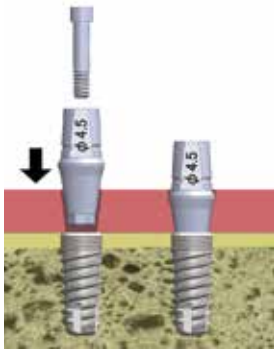

- Connect the Ready abutment and/or abutment screw to the implant body by using the carrier of the attachment. Use the torque wrench to tighten the screw. (20 N·cm maximum).

- ⚠ Prior to placement, check that the top of the implant body is free from tissue or residue.
- ⚠ If required, take an X-ray to confirm the connection between the abutment and the implant body.
- ⚠ Check that the shape and position of the abutment does not result in excessive lateral force on the abutment and consequently on the implant body.

- ⚠ Always make sure that the interior of the implant contains no residues of any dental or other materials. If necessary clean and dry appropriately.

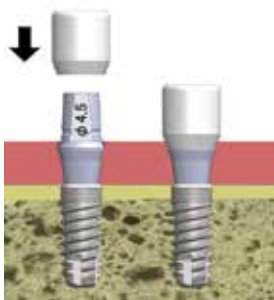

3. Taking the impression (see page 24 and following).

4. Placement of Ready abutment protective cap

- Attach the Ready abutment protective cap onto the abutment.



5. Provisional luting of the final prosthesis

- Lute prosthesis with provisional cement such as GC Freegenol, carefully removing excess cement from the margins.

2.2 Screw-retained superstructure

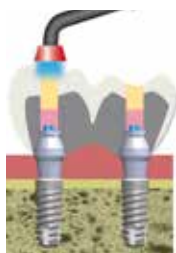
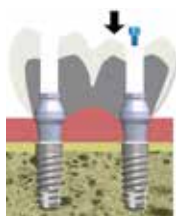
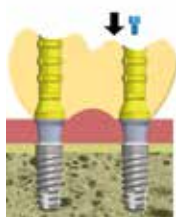
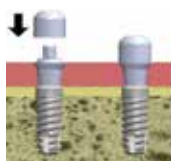
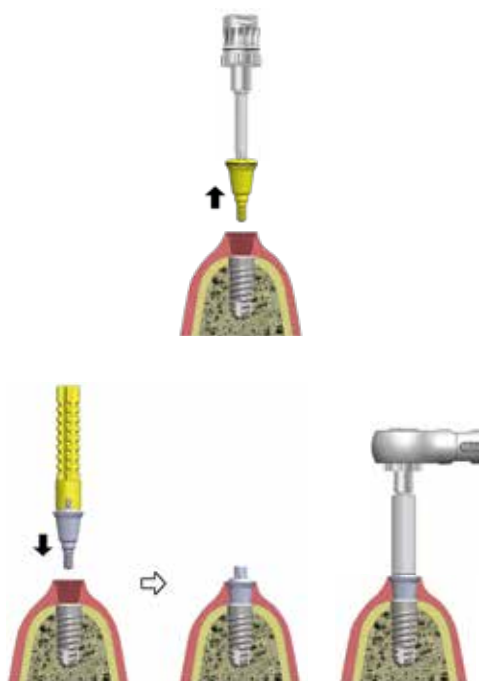

SR abutment

1. Preparation

- Remove the healing screw with a screw driver.
- Select the appropriate height of SR abutment for each clinical case.
Make sure all impression material has been thoroughly removed before replacing the healing screw

2. Placement of the abutment

- Connect the SR abutment and/or abutment screw to the implant body by using the carrier of the attachment. Use the torque wrench to tighten the screw. (20 N·cm maximum).
- ⚠ Prior to placement, check that the top of the implant body is free of tissue or residue.
- ⚠ If required, take an X-ray to confirm the connection between the abutment and the implant body.
- ⚠ Check the shape and position of the abutment to avoid excess lateral force on the implant body.

3. Taking the impression

(see page 24 and following)

4. Placement of SR abutment protective cap

- Install SR abutment protective cap on the abutment.

5. Temporary wearing of prosthesis

- After the contact point has been adjusted in the mouth, tighten the SR screw by hand using a screw driver.
- Adjust the dental occlusion, insert cotton wool pellet into the access hole and seal it temporarily with block out material.
- ⚠ Check that the top of the abutment is free of tissue or residue.
- ⚠ If required, take an X-ray to confirm connection.

6. Final tightening of the SR screw

- After one week or more, remove the block out material and cotton wool pellet.
- Confirm the SR screw is not becoming loose. Tighten the SR screw using the screw driver with a torque wrench. (10 N·cm maximum).

7. Installation of the final prosthesis

- Put the silicone (or other buffer material) on the SR screw, and completely block the access hole with resin etc.
- Do the final adjustment of the occlusion.

UCLA abutment

1. Taking the impression

(see page 24 and following)

- After taking the impression, re-attach the healing screw.
- ⚠ Make sure all impression material has been removed before replacing healing screw or any other abutment.

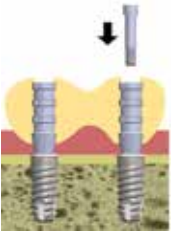

2. Temporary wearing of prosthesis

- After the contact point has been adjusted in the mouth, tighten the abutment screw by hand, using the screw driver.
- Adjust the dental occlusion, insert cotton wool pellet into the access hole and seal it temporarily with block out material.
- ⚠ Check that the top of the abutment is free from tissue or residue.
- ⚠ If required, take an X-ray to confirm the connection.

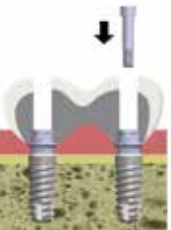

3. Final tightening of the abutment screw

- After one week or more, remove the block out material and cotton wool pellet.
- Confirm the abutment screw is not loosening, tighten the abutment screw using a screw driver with torque wrench. (20 N·cm maximum).

4. Installation of the final prosthesis

- Fix the final prosthesis with temporary cement such as GC FujiTemp / GC Freegenol.
- ⚠ Remove excess cement carefully.



3. Impression taking

- Take an impression for the purpose of reproducing the position of the installed implant body / Ready abutment / SR abutment with a model for use when fabricating the superstructure.
 - The implant analog having the same shape as the head of the implant body is installed in the model in the site of the implant body.
 - The hex located inside the implant body can be reproduced in the model.
 - The Ready abutment analog / SR abutment analog having the same shape as the head of the abutment body is installed in the model in the site of abutment.
-
- After taking the impression, re-attach the healing screw or appropriate (temporary) abutment.
- ⚠ Make sure all the impression material has been removed before replacing the healing screw or any other abutment and superstructure.

3-1. Transfer impression <implant level>

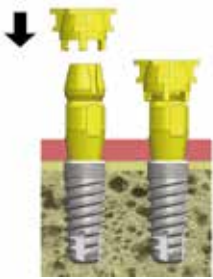

1. Attach the impression coping

- Remove the healing screw and select the appropriate impression coping.
- Fit implant impression coping with transfer screw.
- Attach transfer cap onto impression coping.

- ⚠ Check that there is no tissue or residue on the top of the implant body.
- ⚠ Block out residual teeth if necessary.

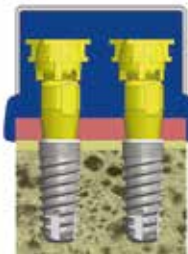

2. Taking the impression

- Use EXA'lence™ impression material from GC.

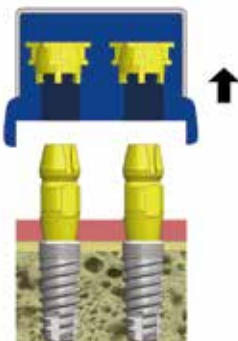

3. Removing the tray

- Check that the transfer cap remains in the impression material.
- Remove the impression coping, place the healing screw and tighten with a torque of 10 N·cm.
- Fabricate a model in the lab.

- ⚠ Do not remove the transfer cap from the impression material.
- ⚠ Rinse any saliva etc. from the impression surface and confirm that an accurate impression has been taken.

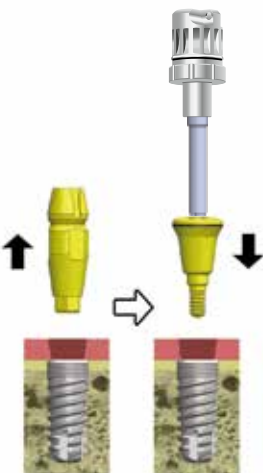

- After taking the impression, re-attach the healing screw.

- ⚠ Make sure all the impression material has been removed before replacing the healing screw or any abutment.

3-2. Pick-up impression <implant level>

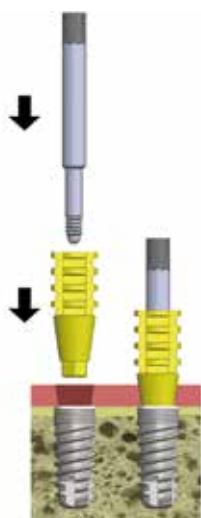

1. Coping selection based on implant impression

- Remove the healing screw and select the appropriate impression coping.
- Fit the implant impression coping pick up using a guide pin.

- ⚠ Check that there is no tissue or residue on the top of the implant body.
- ⚠ Block out residual teeth if necessary.

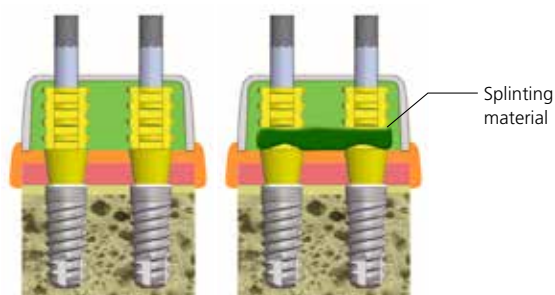

2. Taking the impression

- Check correct seating of the impression copings and guide pins.
- Optionally connect the impression copings using an appropriate splinting material.
- Check that the guide pins pass through the tray.
- Take the impression in the usual manner.

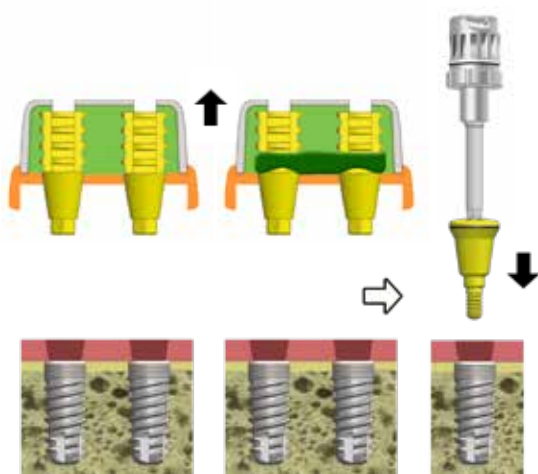

3. Removing the tray

- Check that the impression material has fully set, then remove the guide pin with the screw driver and remove the impression tray.
- Place the healing screw and tighten with a torque of 10 N-cm.
- Fabricate a model in the lab.
- ⚠ Check that you have unscrewed the guide pins.
- ⚠ For safety reasons it is recommended to remove the guide pins from the impression to prevent accidental swallowing or aspiration while taking out the impression.
- ⚠ Rinse any saliva etc. from the impression surface and confirm that an accurate impression has been taken.
- After taking the impression, re-attach the healing screw.
- ⚠ Make sure all the impression material has been removed before replacing the healing screw.

3-3. Transfer impression <abutment level>

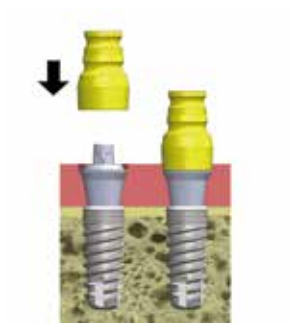

1. Attach the impression coping

- Attach the SR abutment impression coping to the SR abutment.

- ⚠ Check that there is no tissue or residue on the top of the implant body.
- ⚠ Block out residual teeth if necessary.



2. Taking the impression

- Use EXA'lence™ impression material from GC.

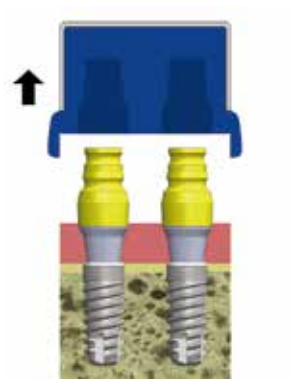

3. Removing the tray

- Remove the impression coping and replace the SR abutment protective cap.
- Fabricate a model in the lab.
- ⚠ Rinse any saliva etc. from the impression surface and confirm that an accurate impression has been taken.

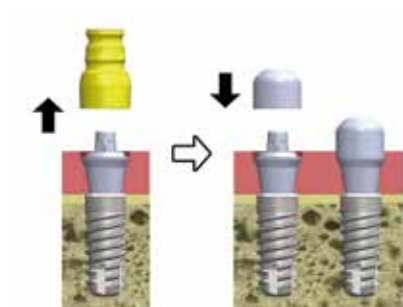

- ⚠ Make sure all impression material has been removed from implant areas.

3-4. Pick-up impression <abutment level>

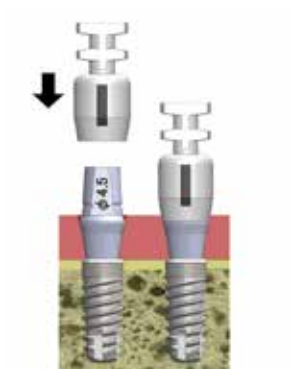

1a. Attach the Ready abutment impression cap

- Attach the Ready abutment impression cap to the Ready abutment.
- ⚠ Block out residual teeth if necessary.

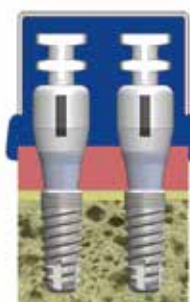

2a. Taking the impression

- Use EXA'lence™ impression material from GC.
- Check that the impression cap remains in the impression material.
- Place the Ready abutment protective cap.
- Fabricate a model in the lab.
- ⚠ Do not remove the impression cap from the impression material.
- ⚠ Rinse any saliva etc. from the impression surface and confirm that an accurate impression has been taken.

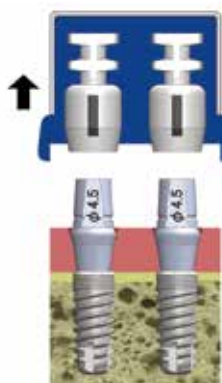

- ⚠ Make sure all the impression material has been removed from the implant areas.

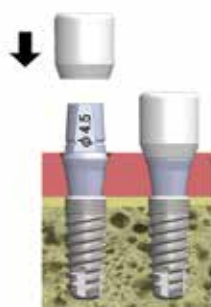

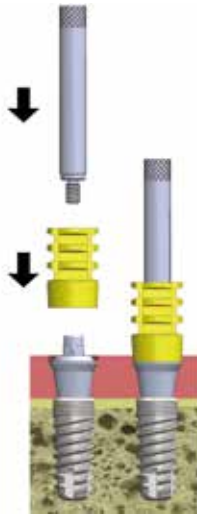

1b. Attach the SR abutment impression coping pick up

- Fit the SR abutment impression coping pick up using an SR abutment guide pin.
- ⚠ Check that there is no tissue or residue on the top of the implant body.
- ⚠ Block out residual teeth if necessary.

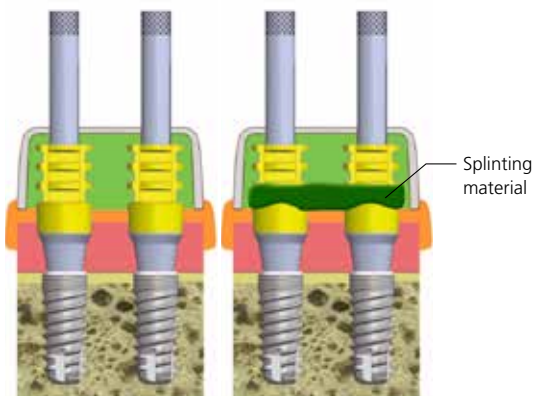

2b. Taking the impression

- Check correct seating of the impression copings and guide pins
- Optionally connect the impression copings using an appropriate splinting material.
- Check that the guide pins pass through the tray.
- Take the impression in the usual manner.

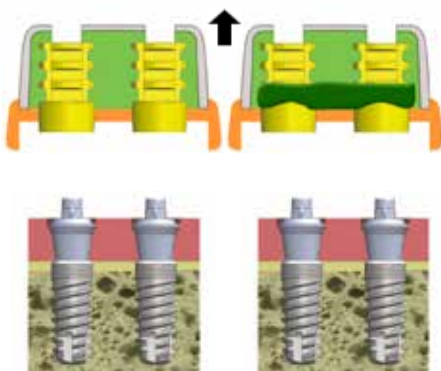

3b. Removing the tray

- Check that the impression material has fully set, then remove the guide pins using a screw driver and remove the impression tray.
- Place the SR abutment protective cap.
- Fabricate a model in the lab.
- ⚠ Check that you have unscrewed the guide pins.
- ⚠ For safety reasons it is recommended to remove the guide pins from the impression to prevent accidental swallowing or aspiration while taking out the impression.
- ⚠ Rinse any saliva etc. from the impression surface and confirm that an accurate impression has been taken.
- ⚠ Make sure all the impression material has been removed from the implant areas.

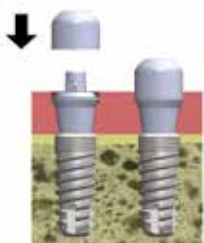

V Management after attaching the superstructure

1. The importance of post-operative management for implants

Properly managed implants have a high level of success. While there are a large number of reports related to procedural accidents after operations are complete, post-operative management is essential for the long-term success and maintenance of implants. The patient needs to be instructed regarding the importance of keeping the oral environment in good condition before the start of the operation. Cooperation between dental surgeons, dental hygienists and patients is essential.

2. Purpose of post-operative management for implants

Post-operative management has two main purposes. The idea of prevention is the most important concept of post-operative management.

- 1) Early detection of defective components.
- 2) Prevention of tissue inflammation around the implant caused by infections or excessive loading.

3. Examination frequency

Postoperative management commences as soon as the adjustments after attaching the superstructure are complete. Examinations of the tissue around the implant or occlusal contact should be conducted every six months. Even if no obvious symptoms are identified, X-ray images should be taken yearly to observe the condition of the bone around the top of the implant. Instructions regarding proper oral hygiene should be given as needed. If an appropriate oral environment has not been maintained, intervals between examinations should be shortened.

4. Examination items and methods

4-1. Examinations of the implant superstructure

In the event of:

- (1) Strange sensation along the superstructure: check with medical interview.
- (2) Wearing of the superstructure, fractures: check with visual examination.
- (3) Loose screws: check with visual and manual examination.
- (4) Dirt in the joints of the superstructure: check with visual examination.
- (5) Blocked access hole (for screw-retained implants): check with visual examination, probe.
- (6) Occlusal contact: examination of occlusal contact is conducted by having the patient bite on ordinary occluding paper and using a pulling test with 10 µm gold foil to check occlusion in detail (intercuspal position, mandibular motion).

4-2. Examinations of tissue around the implant

In the event of:

- (1) Pain, bleeding, swelling or other symptoms around the implant: check with medical interview, visual and manual examination.
- (2) Tone, shape and oral hygiene of the gingiva: check with visual examination, diagnose any inflammation.
- (3) Effusion, bleeding, pus discharge: check by applying pressure to the gingiva with an appropriate instrument. If inflammation is observed, check the surrounding tissue with a plastic perio probe and check with touch examination by applying 20 g or less pressure within the pocket.
- (4) Plaque build-up around the implant, calculus deposition: check with visual and touch examination.
- (5) Bone absorption: check with radiograph examination.

5. Treatment

5-1. Treatment related to implant superstructures

- (1) Fractured superstructure: repair or replace.
- (2) Loose screws: remove the superstructure and any dirt within the joint. Use an ultra-sonic cleaner for superstructure dirt and clean the oral components with a swab or toothbrush. Check whether there are no damaged or worn sections, and fasten the screws again to the specified torque.
- (3) Occlusal contact: adjust the occlusal contact if needed, taking into account balance with the residual teeth. Extra care is required for premature contact with the implant due to movement in residual teeth.

5-2. Treatment of tissue around the implant

Patient conditions and treatment can be categorized into three major stages depending on the severity of the conditions.

(1) Mucositis around the implant

Patient condition: inflammatory symptoms such as swelling or pus discharge from the tissue around the implant, however no changes observed in X-ray diagnosis of the bone supporting the implant.

Treatment: inflammation can be reduced with oral hygiene care and occlusal management. If plaque deposition has been observed, conduct professional mechanical and chemical cleaning and instruct the patient to use brushing for appropriate home care. In addition to toothbrushes, instruct the patient to use extra dental floss and interdental brushes. Dental hygienists cleaning implants must take extra care not to damage the implant with metallic instruments. If needed, the shape of the superstructure may be adjusted to improve cleaning.

(2) Minor inflammation around the implant

Patient condition: The implant is stable with no sign of mobility, however bone resorption has been observed in part of the bone supporting the implant.

Treatment: while inflammation can be mostly reduced with oral hygiene care and occlusal management, the implant surface should be sterilized as much as possible using mechanical and chemical cleaning around the areas of bone resorption. Bone regeneration can be applied in areas with bone defects if necessary. If the inflammation cannot be halted to an acceptable degree removal of the implant should be considered as one method of limiting progress of further bone resorption.

(3) Major inflammation around implant

Patient condition: Major bone resorption and implant mobility observed.

Treatment: the bone attachments have resorbed and must be removed. Remove the implant, as well as the granulation tissue, and wait for the area around the removed implant to heal. Conduct an implant treatment adaptability diagnosis after the area as healed if the patient desires so, and examine whether further treatment is possible.

VI Procedural problems

Procedural problems during operations are similar to those in other oral surgical procedures, and may result in infections, nerve injuries, postoperative bleeding or other symptoms. The following symptoms may result from some typical postoperative procedural problems following installation of implants.

Exposed cover screws

If screws become exposed several weeks after the operation, the surrounding mucous membrane can be extended with resuturing to seal the area. The surfaces of the cover screws becoming exposed after this time must be kept clean. Instruct the patient to clean the surfaces of the exposed cover screws with a cotton swab dipped in benzethonium chloride or a similar solution. When doing so, regularly check for plaque build up or inflammation of the surrounding mucous membrane.

If osseointegration has not been achieved or has been lost

Osseointegration may not be achieved if the implant appears to have become mobile and then must be removed. Remove the implant body by inserting an implant driver, then rotating the handpiece in reverse at a speed of 25 rpm or less. The implant can be removed with the abutment in place in cases of severe mobility.

Removal of an implant after osseointegration has been achieved

If, for some reason, it is necessary to remove an implant after osseointegration has been achieved, use a trephine to cut away bone around the implant at a speed of 1200 rpm or less under running water before removing it.

VII Disinfection/Sterilization of Components and Instruments

Components

The components listed below are designed for **single use** and **delivered non-sterile**. They must be cleaned and sterilized **before** use.

Metal Implant Impression Coping, Implant Guide Pin, Transfer Screw, SR Abutment Impression Coping, SR Abutment Protective Cap, SR Abutment Guide Pin, UCLA Abutment, Provi Abutment, Prep Abutment, Abutment Screw, Ready Abutment, Smart Abutment, Smart Abutment 15°, SR Ti Screw, SR Abutment Provi Coping Ti, Ready Abutment, Blend-/Hybrid abutment, Universal Blend-/Hybrid abutment, Scanpost for Universal Blend-/ Hybrid Abutment

Plastic Transfer Cap, Ready Abutment Impression Cap, Ready Abutment Protective Cap, SR Abutment Provi Coping Plastic, Ball Attachment Cap, O-Ring (Ball Attachment)

Please refer to the actual 'Instructions for Use' (IFU) supplied with the components.

Instruments

The instruments listed below are **reusable** and **delivered non-sterile**. They must be cleaned and sterilized **before and after** use.

Screw Drivers, Implant Drivers, Abutment Drivers, Direction and Depth Indicator, Depth Gauge, Torque Wrench, Abutment Remover, Burs and Drills, Drill Stoppers and Drill Stopper Holders, Drill Extension, Prosthetic box, Surgical Box

Please refer to the actual 'Instructions for Use' (IFU) supplied with the instruments.

Notes

A series of horizontal dotted lines for writing notes.

Notes

A series of horizontal dotted lines for writing notes.

For more information please contact:

GC Tech.Europe GmbH

Harkortstr. 2
D-58339 Breckerfeld
Germany
Tel.: +49 2338 801980
Fax: +49 2338 801985
E-Mail: info@gctech.eu
www.gctech.eu

